

DATA SHEET

vibro-meter®

CA280 piezoelectric accelerometer



KEY FEATURES AND BENEFITS

- From the vibro-meter® product line
- High sensitivity: 100 pC/g
- Frequency response: 0.5 to 6000 Hz
- Temperature range: -60 to 260°C
- Ex certified for use in potentially explosive atmospheres
- Symmetrical sensor with internal case insulation and differential output
- Hermetically welded
AISI 316L stainless-steel case
- Available as a sensor only version (no integral cable) and versions with integral cable

APPLICATIONS

- Vibration monitoring for low amplitude and analytical applications
- Hazardous areas (potentially explosive atmospheres) and/or harsh industrial environments

DESCRIPTION

The CA280 is a piezoelectric accelerometer from Meggitt's vibro-meter® product line.

The CA280 sensor features a symmetrical shear-mode measuring element with internal case insulation in a stainless-steel case (housing).

The CA280 is available as a sensor only or in versions fitted with an integral low-noise cable that is protected by a flexible stainless-steel protection hose (leaktight) which is hermetically welded to the sensor to produce a sealed leaktight assembly. The sensor only version allows different cable assemblies to be used depending on the temperature requirements of the application.

All versions of the CA280 are Ex certified for installation in potentially explosive atmospheres (hazardous areas).

The CA280 piezoelectric accelerometer sensor is designed for vibration monitoring and measurement when high instrument sensitivity and low base-strain sensitivity are required.

For specific applications, contact your local Meggitt representative.



Information contained in this document may be subject to export control regulations of the European Union, USA or other countries. Each recipient of this document is responsible for ensuring that transfer or use of any information contained in this document complies with all relevant export control regulations. ECN N/A.

SPECIFICATIONS

General

Input power requirements	: None
Signal transmission	: 2-pin system, insulated from case, charge output
Signal processing	: Charge converter (IPC70x signal conditioner)

Operating

(At 23°C ±5°C, 73°F ±9°F)

Sensitivity (at 120 Hz with 5 g, see Calibration on page 4)	: 100 pC/g ±5%
Dynamic measurement range	: 0.01 to 500 g peak
Linearity	
• 0.01 to 100 g (peak)	: ±1%
• 100 to 500 g (peak)	: ±2%
Transverse sensitivity	: <3%
Resonant frequency	: >20 kHz nominal
Frequency response	
• 0.5 to 6000 Hz	: ±5% (lower cutoff frequency is determined by the signal conditioner)
• Typical deviation at 10 kHz	: +15%
Internal insulation resistance	: 10 ⁹ Ω minimum
Capacitance	
• Sensor only version	: 15 pF nom. between pin (+ or -) and case (ground). 8000 pF max. between pins (+ and -).
• Versions with integral cable	: 15 pF nom. between pin (+ or -) and case (ground). 8000 pF max. between pins (+ and -) + 200 pF/m of integral cable.

Environmental

Temperature range	
• Continuous operation	: -60 to +260°C (-76 to +500°F)
• Short-term survival (15 minutes maximum)	: -70 to +290°C (-94 to +554°F)
Temperature sensitivity error (with respect to 23°C, 73°F)	
• -60°C to +260°C	: ±10%
Corrosion, humidity	: AISI 316L stainless steel, hermetically welded
Base-strain sensitivity	: 0.8 x 10 ⁻³ g/με
Shock acceleration	: <1000 g peak (half sine, 1 ms duration) along sensitive axis

SPECIFICATIONS (continued)

Potentially explosive atmospheres

Ex certified for use in hazardous areas

Type of protection Ex i: intrinsic safety		
Europe	EC type examination certificate	 II 1 G (Zones 0, 1, 2) Ex ia IIC T6...T2 Ga KEMA 04 ATEX 1055
International	IECEX certificate of conformity	Ex ia IIC T6...T2 Ga IECEX DEK 15.0029 <i>Note: Not engraved on the product marking.</i>
North America	cCSAus certificate	Class I, Division 1, Groups A, B, C, D Ex ia IIC T6...T2 Ga Class I, Zone 0 AEx ia IIC T6...T2 Ga cCSAus 1514310
Korea	KGS certificate of conformity	Ex ia IIC T6...T2 KGS 17-GA4BO-0323X <i>Note: Not engraved on the product marking.</i>
Russian Federation	EAЭC RU certificate of conformity	0Ex ia IIC T6...T2 Ga X EAЭC RU C-CH.AΔ07.B.03042/21 <i>Note: Not engraved on the product marking, except for 144-280-000-2xx.</i>

Type of protection Ex nA: non-sparking		
Europe	Voluntary type examination certificate	 II 3 G (Zone 2) Ex nA IIC T6...T2 Gc LCIE 09 ATEX 1047 X
International	IECEX certificate of conformity	Ex nA IIC T6...T2 Gc IECEX LCI 10.0021X <i>Note: Not engraved on the product marking.</i>
North America	cCSAus certificate	Class I, Division 2, Groups A, B, C, D Ex nA IIC T6...T2 Gc Class I, Zone 2 AEx nA IIC T6...T2 Gc cCSAus 1514310
Russian Federation	EAЭC RU certificate of conformity	2Ex nA IIC T6...T2 Gc EAЭC RU C-CH.AΔ07.B.03042/21 <i>Note: Not engraved on the product marking, except for 144-280-000-2xx.</i>

 For specific parameters of the mode of protection concerned and special conditions for safe use, refer to the Ex certificates that are available from Meggitt SA.

 For the most recent information on the Ex certifications that are applicable to this product, refer to the Ex product register (PL-1511) document that is available from Meggitt SA.

SPECIFICATIONS *(continued)*

Approvals

Conformity	: European Union (EU) declaration of conformity (CE marking). EAC marking, Eurasian Customs Union (EACU) certificate/ declaration of conformity.
Electromagnetic compatibility (EMC)	: Electromagnetic compatibility (2014/30/EU). EN 61000-6-2:2005. EN 61000-6-4:2007 + A1:2011. TR CU 020/2011.
Electrical safety	: ATEX directive (2014/34/EU) and low-voltage (2014/35/EU). EN 61010-1:2010.
Environmental management	: RoHS compliant (2011/65/EU). EN 50581:2012.
Hazardous areas	: ATEX directive (2014/34/EU). Ex approved versions (see Potentially explosive atmospheres on page 3).
Russian federal agency for technical regulation and metrology (Rosstandart)	: Pattern approval certificate OC.C.28.004.A N° 59463

Calibration

Dynamic calibration at factory at 5 g peak and 120 Hz (23°C, 73°F). No subsequent calibration necessary.

Physical

Case (housing) material	: AISI 316L stainless steel
Dimensions	: See Mechanical drawings on page 5
Weight	
• Sensor	: 75 g (0.17 lb) approx.
• Cable	: 135 g/m (0.30 lb/m) approx.
Mounting	: Three M4 × 16 Allen screws and three M4 spring lock washers with a nominal tightening torque of 4 N•m (3 lb-ft). (ARINC [®] 554 fixation.) Note: Electrical insulation of the mounting surface is not required. See Mounting adaptors in Accessories on page 6 . Refer also to the <i>Vibration measurement chains using CAxxx piezoelectric accelerometers installation manual</i> .
Connector	
• Sensor only version	: High-temperature, rugged circular, threaded coupling, 2-pin connector with keyway (vibro-meter 7/16"-27UNS-2A / CG505 (military standard). Mates with connectors used by the recommended cable assemblies (vibro-meter [®] 7/16"-27UNS-2B or CG505).
• Integral cable versions	: Terminated with flying leads

MECHANICAL DRAWINGS

Sensor only version

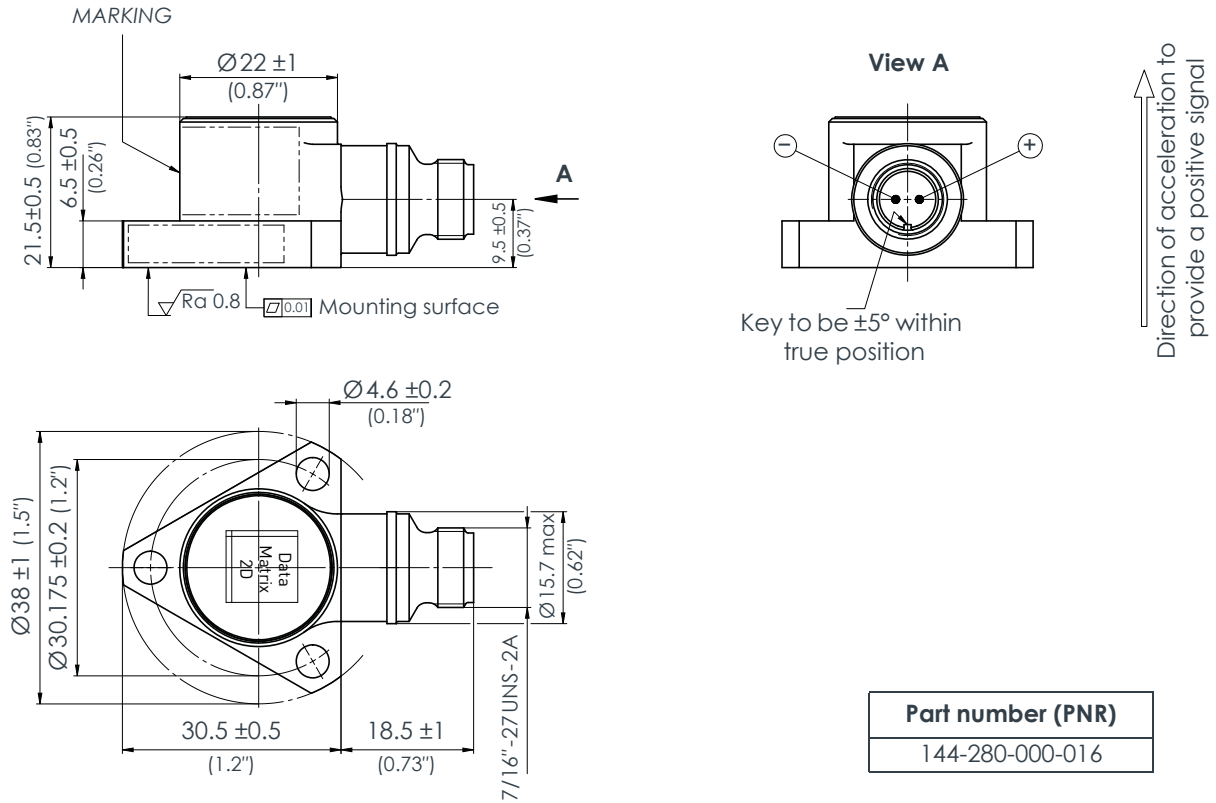

Note: All dimensions are in mm (in) unless otherwise stated.

Versions with integral cable

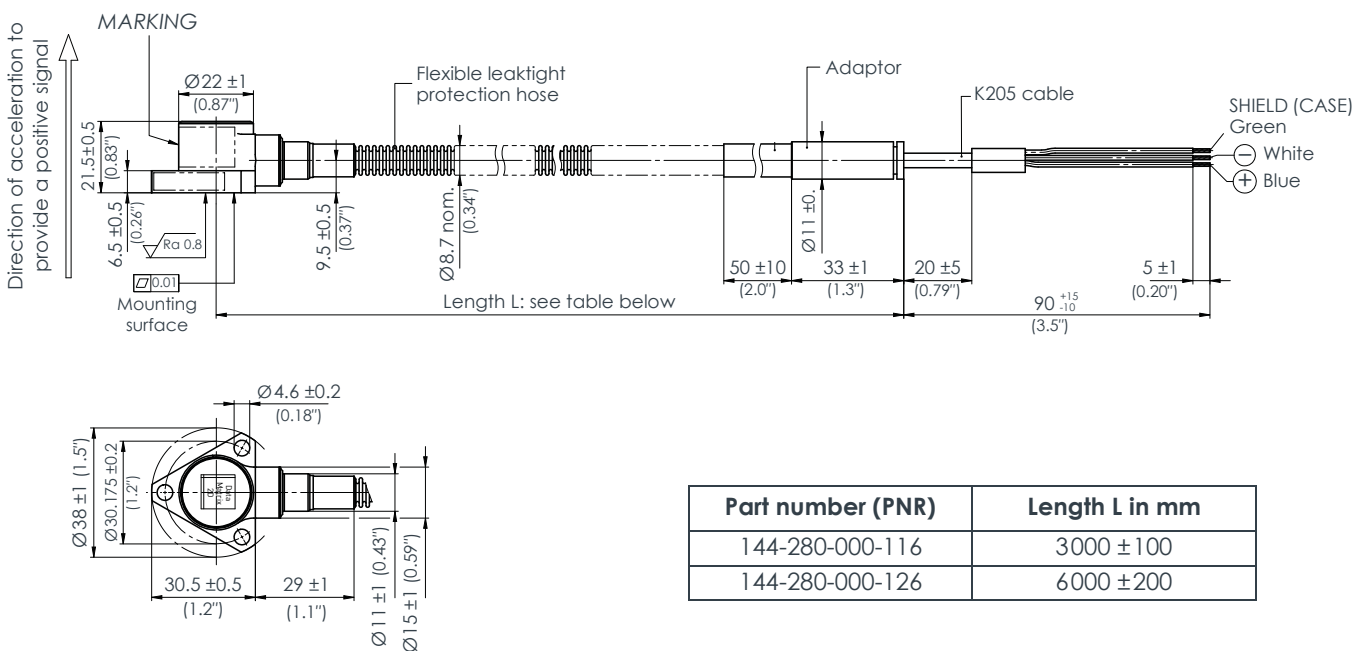

Note: All dimensions are in mm (in) unless otherwise stated.

ORDERING INFORMATION

To order please specify

Type	Designation	Part number (PNR)
CA280	Different versions of the piezoelectric accelerometer:	
	Sensor only version (no integral cable)	144-280-000-016
	Version with 3 m integral cable	144-280-000-116
	Version with 6 m integral cable	144-280-000-126

Note: The integral cable is a low-noise, shielded, twisted pair cable (K205) that is terminated with flying leads. The integral cable is protected by a sealed flexible protection hose (leaktight) made of stainless steel that is hermetically welded to the sensor.

ACCESSORIES

Item	Type	Part number (PNR)
Mounting adaptors	TA104 (Mounting adapter for CA/CE13x and CA/CE28x, stainless-steel hexagonal base with M8 stud). Refer to product drawing 144-136-301-101.	144-136-301-101
	TA105 (Mounting adapter for CA/CE13x and CA/CE28x, thermally isolating base (300°C, 572°F)). Refer to product drawing 144-136-302-101.	144-136-302-101

Meggitt (Meggitt PLC) is a leading international engineering company, headquartered in England, that designs and delivers high-performance components and subsystems for aerospace, defence and selected energy markets. Meggitt comprises four customer-aligned divisions: Airframe Systems, Engine Systems, Energy & Equipment and Services & Support.

The Energy & Equipment division includes the Energy Sensing and Controls product group that specialises in sensing and monitoring solutions for a broad range of energy infrastructure, and control valves for industrial gas turbines, primarily for the Power Generation, Oil & Gas and Services markets. Energy & Equipment is headquartered in Switzerland (Meggitt SA) and incorporates the vibro-meter[®] product line, which has over 65 years of sensor and systems expertise and is trusted by original equipment manufacturers (OEMs) globally.



All information in this document, such as descriptions, specifications, drawings, recommendations and other statements, is believed to be reliable and is stated in good faith as being approximately correct, but is not binding on Meggitt (Meggitt SA) unless expressly agreed in writing. Before acquiring and/or using this product, you must evaluate it and determine if it is suitable for your intended application. You should also check our website at www.meggittsensing.com/energy for any updates to data sheets, certificates, product drawings, user manuals, service bulletins and/or other instructions affecting the product.

Unless otherwise expressly agreed in writing with Meggitt SA, you assume all risks and liability associated with use of the product. Any recommendations and advice given without charge, whilst given in good faith, are not binding on Meggitt SA. Meggitt (Meggitt SA) takes no responsibility for any statements related to the product which are not contained in a current Meggitt SA publication, nor for any statements contained in extracts, summaries, translations or any other documents not authored and produced by Meggitt SA.

The certifications and warranties applicable to the products supplied by Meggitt SA are valid only for new products purchased directly from Meggitt SA or from an authorised distributor of Meggitt SA.

In this publication, a dot (.) is used as the decimal separator and thousands are separated by thin spaces. Example: 12345.67890.

Copyright© 2022 Meggitt SA. All rights reserved. The information contained in this document is subject to change without prior notice.

Sales offices

Meggitt has offices in more than 30 countries. For a complete list, please visit our website.

Local representative

Head office

Meggitt SA
Route de Moncor 4
Case postale
1701 Fribourg
Switzerland

Tel: +41 26 407 11 11

Fax: +41 26 407 13 01

energy@ch.meggitt.com

www.meggittsensing.com/energy

www.meggitt.com

